

# IsoFlex™

MINIMIZING

VIBRATION



APPLICATIONS: MARINE

DEFENSE

INDUSTRIAL

COMMERCIAL

SEISMIC

# GEARguard

FLEX COUPLINGS

---

# INSTALL A FLEXIBLE COUPLING IF YOU WANT TO:

- Reduce the chance of damage to your engine and transmission. Under normal circumstances, a sacrificial flexible coupling should fail before this damage occurs.
- Isolate and minimize drive line vibration, propeller pulse and gear chatter. The result is a much quieter boating experience.
- Enhance drive bearing service life by reducing wear.
- Assist engine mounts to do their job by allowing controlled engine movement.
- Help alleviate thrust-induced drive line misalignment.

---

# GEARguard

**FLEX COUPLINGS**

---

# INSTALL AN ISOFLEX GEARguard COUPLING BECAUSE:

- IsoFlex has developed a specialized machining technique to eliminate run-out and consequent vibration.
- With IsoFlex internal hex-shaped fittings, the possibility of inserts turning in the coupling is minimized.
- IsoFlex couplings are easy to install. No cutting is required and your boat can remain in the water.
- IsoFlex takes the guesswork out of selecting the right coupling for your application. Please follow the “How to Measure” instructions beginning on page 5.
- Most 8-Bolt, 10-Bolt and large 6-Bolt couplings have been designed with precision machined steel index rings which maximize dimensional stability and minimize run-out.

---

# CATALOG

# CONTENTS

## **I have a coupling I would like to replace.**

Please turn to pages 18 through 20 for cross reference charts.

Here you will find the correct GEARguard coupling to replace a Globe DriveSaver and other commonly used couplings.

## **I have my transmission information. Which coupling do I need?**

Please turn to pages 21 through 24 for cross reference charts.

Here you will find the correct GEARguard coupling to use with a variety of transmissions, organized by manufacturer.

## **Will it fit?**

If you do not find a cross reference “fit”, please turn to pages 5 through 9 for step-by-step measurement instructions.

Once you have completed this information describing your gearbox flange, you can refer to page 10 for 4-Bolt coupling information, page 12 for 6-Bolt coupling information, page 14 for 8-Bolt coupling information and page 16 for 10-Bolt coupling information. Information about Spicer U-Joint couplings can be found on page 17.

## **Will it work?**

IsoFlex Technologies strongly suggests that you calculate the torque rating for your specific installation.

Please turn to pages 7 and 8 for instructions on how to calculate the torque rating of your current drive train.

Then proceed to page 11 for the corresponding torque ratings of IsoFlex 4-Bolt couplings, page 13 for 6-Bolt torque ratings, page 15 for 8-Bolt couplings and page 16 for 10-Bolt couplings.

As long as your torque rating is less than or equal to that of the IsoFlex coupling you wish to order, your IsoFlex product should work perfectly. If your torque exceeds that of the posted IsoFlex rating for your coupling, please contact IsoFlex or your local distributor to discuss a custom coupling.

## **How do I install it?**

Please turn to pages 25 through 29 to read a general set of installation instructions. Instructions specific to your IsoFlex GEARguard coupling are included with each product.

---

# GEARguard

FLEX COUPLINGS

# HOW TO MEASURE:

1

1. Bolt Circle Diameter:  
\_\_\_\_\_

2. Number of Bolt Holes  
in the Gearbox Flange: \_\_\_\_\_

3. Size of Bolt Holes  
in the Gearbox Flange: \_\_\_\_\_

Before ordering, you will need to examine your current *gearbox flange* and propeller shaft flange. In order to determine the following information, it will be necessary to remove all of the bolts from the flanges. Slide the propeller shaft flange aft of the *gearbox flange* approximately 50mm. All measurements are best taken with a caliper. (Record your findings in the measurement box on each page).

## 1. Bolt Circle Diameter - 4-Bolt, 6-Bolt and 8-Bolt Flanges

In each *gearbox flange*, you should find that the hole pattern aligns one hole directly across from another on the opposite side of the flange. Measure the outside edge of one hole to the inside edge of the hole directly across from it. This is the bolt circle diameter. It is always a good idea to measure two different sets of holes and compare results.

## 2. Count number of bolt holes in the *gearbox flange*.

## 3. Size of Bolt Holes in the Flange Diameter

Simply measure the inside diameter of one or more of the holes in the *gearbox flange* and record result here.

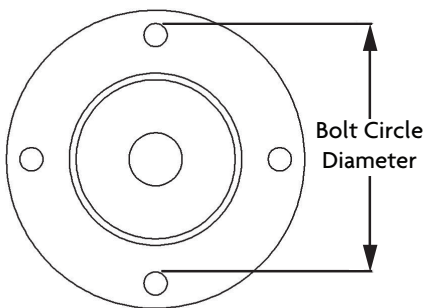

**4-Bolt  
Gearbox Flange**

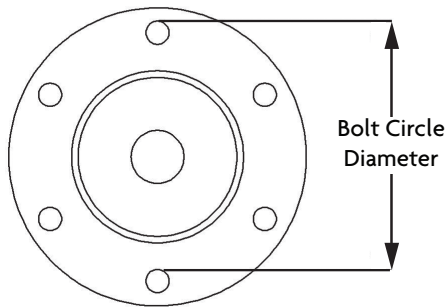

**6-Bolt  
Gearbox Flange**

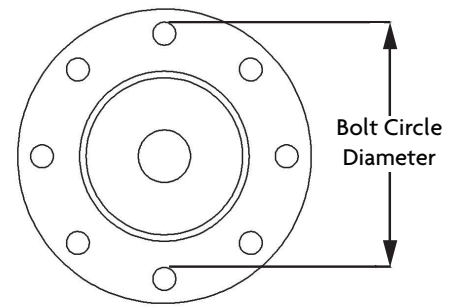

**8-Bolt  
Gearbox Flange**

# HOW TO MEASURE:

# 2

Gearbox Flange Index Ring Type -

Male or Female: \_\_\_\_\_

4. Gearbox Flange Index Ring Outside  
Diameter/Male: \_\_\_\_\_

5. Gearbox Flange Index Ring Inside  
Diameter/Female: \_\_\_\_\_

6. Propeller Shaft Flange Thickness:  
\_\_\_\_\_

#### 4. Index/Spigot/ Pilot Diameter - Male

Using a caliper, measure the outside diameter of the metal index ring on the face of the gearbox flange.

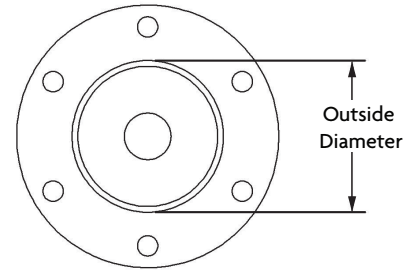

#### 5. Index/Spigot/ Pilot Diameter - Female

Using a caliper, measure the inside diameter of the circular cavity in the center of the gearbox flange.

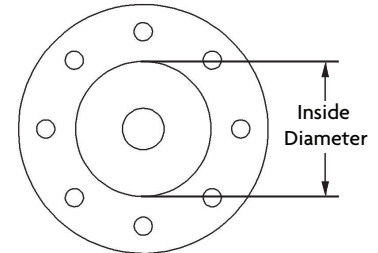

#### 6. Propeller Shaft Flange Thickness

Using a caliper, measure the propeller shaft flange thickness at its edge. If the bolts you received with your coupling are too short for the flange thickness, please contact IsoFlex or your local distributor.

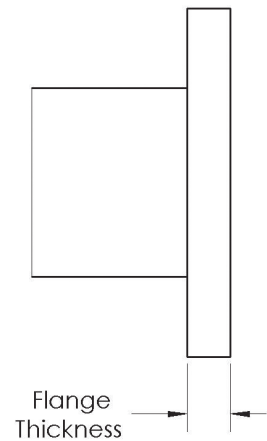

# GEARguard

FLEX COUPLINGS

# HOW TO MEASURE: 3

9. Drive Train Measurements:

A. Propeller clearance from rudder:

\_\_\_\_\_

B. Propeller clearance from strut:

\_\_\_\_\_

10. Maximum Torque Calculation:

\_\_\_\_\_

## Conversion factors:

1 ft-lb = 1.356 Nm	1 hp = 0.746 kW
1 Nm = 0.7376 ft-lb	1 kW = 1.34 hp

### To determine the approximate engine/gearbox output torque in ft-lbs, use one of the formulae below:

$$\text{Torque (ft-lb)} = \frac{(\text{Engine power (hp)} \times 5252 \times \text{gear reduction ratio})}{\text{Engine RPM}}$$

$$\text{Torque (ft-lb)} = \frac{(\text{Engine power (kW)} \times 7038 \times \text{gear reduction ratio})}{\text{Engine RPM}}$$

$$\text{Torque (ft-lb)} = 0.737 \times \text{Torque (Nm)}$$

## 9. Drive Train Measurements

In some instances, the propeller shaft may have to be trimmed before installing the IsoFlex coupling. There are two reasons for this:

### A. Propeller Clearance from Rudder

According to naval architecture guidelines, the rudder should be at least 20% of the propeller shaft diameter aft of the propeller for proper water flow off the prop and onto the rudder. This should minimize vibration and cavitation on the rudder.

### B. Propeller Clearance from Strut

Just as important, the front end of the propeller should be no more than one shaft diameter aft of the strut. This is to prevent shaft vibration. The exposed shaft may be a bit longer to accommodate a shaft zinc, but that is all.

## 10. Torque Calculation

For the GEARguard coupling to work correctly, it must first be strong enough to meet the torque rating of your installation. That is, it must be able to carry the torque loads generated by the engine/transmission during normal operation.

Before installing any drive line coupling, you should first determine the "maximum allowable" torque rating of your engine/transmission. Published documentation for torque rating usually states the most conservative continuous torque rating. However, IsoFlex suggests that you take the time to calculate the rating for your specific installation.

Please use any of the formulae below to complete this calculation, noting the result in ft-lbs or Nm.

### To determine the approximate engine/gearbox output torque in Nm, use one of the formulae below:

$$\text{Torque (Nm)} = \frac{(\text{Engine power (hp)} \times 7124 \times \text{gear reduction ratio})}{\text{Engine RPM}}$$

$$\text{Torque (Nm)} = \frac{(\text{Engine power (kW)} \times 9550 \times \text{gear reduction ratio})}{\text{Engine RPM}}$$

$$\text{Torque (Nm)} = 1.356 \times \text{Torque (ft-lb)}$$

# HOW TO MEASURE: 4

Once you have identified maximum output torque for your application, see the definitions below to determine which description of normal operation best fits your vessel.

## **Pleasure Craft**

Planing hulls where full throttle operation is less than 5% of total operational time. Couplings for these vessels are rated to operate at 85% of maximum allowable working torque.

## **Medium Duty Craft**

Pleasure or commercial craft (planing, semi-displacement or multi-hulls) such as patrol boats, charter fishing boats, etc. Couplings for these vessels are rated to operate at 75% of maximum allowable working torque.

## **Heavy Duty Craft**

Commercial craft (heavy displacement, semi-displacement or multi-hulls in commercial operation) such as trawlers, ferries, etc. Couplings for these vessels are rated to operate at 50% of maximum allowable working torque.

Next, go to the torque charts on pages 11, 13, 15 and 16. Note the torque rating in the chart which matches 1) the IsoFlex coupling that fits your dimensional characteristics and 2) the type of “craft” you operate (given the above descriptions).

If the IsoFlex torque rating in the chart is equal to or higher than the torque rating produced by your drive train, you can now order your GEARguard coupling.

If the IsoFlex torque rating in the chart is lower than the torque rating produced by your drive train, please contact IsoFlex or your local distributor. IsoFlex may be able to produce a High Torque (HT) coupling for your installation.

# GEARguard

**FLEX COUPLINGS**



# GENERAL COMMENTS

## Bolt Assembly Torque Guide & High Tensile Grades

Coupling bolt size	Recommended assembly torque		High Tensile Grade	
	Ft-lbs	Nm	Imperial	Metric
8mm	10	14		10.9
10mm	31	42		10.9
12mm	34	46		10.9
14mm	65	88		10.9
16mm	83	112		10.9
20mm	150	200		10.9
3/8"	20	27	Grade 5	
7/16"	32	43	Grade 5	
1/2"	47	63	Grade 8	
3/4"	155	210	Grade 8	
7/8"	206	278	Grade 8	
1"	250	338	Grade 8	

### NOTE:

**Over-tensioning ANY of the bolts during assembly (see torque charts above and on page 29 for guidelines) may cause internal damage to the IsoFlex coupling. In extreme cases, the steel inserts may become distorted or spin within the coupling. The result is a coupling that will not function properly.**

### Dimensions

As gearbox manufacturers' dimensions and specifications are subject to change, it is necessary to check all dimensions to ensure fit and suitability of the coupling. All IsoFlex couplings are manufactured from engineering grade polymers. Although these materials are thermoset polymers, there may be dimensional changes from those specified, depending upon ambient temperature conditions.

### Tolerances

The tolerance on all IsoFlex machined index rings is  $\pm 0.002"$  ( $\pm 0.05\text{mm}$ ) @ 25°C (77° F) ambient temperature.

All other dimensions:  $\pm 0.020"$  ( $\pm 0.5\text{mm}$ ) @ 25°C (77° F) ambient temperature.

### INSTALLATION NOTE: Electrical Isolation

**The IsoFlex GEARguard couplings electrically isolate the propeller shaft from the engine and gearbox. If you wish to connect the shaft to the engine, an internal coil spring (option available through IsoFlex) may be fitted.**

### NOTE: T-Bushings

In the charts on page 12, the couplings marked in red are sold with T-bushings sized to fit the bolt holes in the gearbox / propeller shaft flanges.

In some instances, the size of the original bolts used to connect the gearbox flange and the propeller shaft flange are too large to fit within the space constraints of the bolt circle diameter of the IsoFlex flexible couplings. Flexible couplings require twice the number of bolts than the original installation to accommodate the flanges on either side of the coupling.

When this occurs, IsoFlex (per industry guidelines) reduces the diameter size of its assembly bolts. These high-tensile yet smaller diameter replacement bolts will fit loosely within the existing bolt holes of each flange. Accordingly, IsoFlex provides steel, zinc-plated T-bushings to insert in the holes of both flanges. This approach assures that the smaller diameter, high-tensile assembly bolts fit snugly in each flange.

# GEARguard

COUPLINGS

## 4 BOLT - DIMENSIONS



Imperial							
MODEL	GEARBOX FLANGE BOLT CIRCLE DIAMETER	GEARBOX FLANGE BOLT SIZE	GEARBOX FLANGE INDEX RING TYPE	GEARBOX FLANGE INDEX RING DIAMETER	ISOFLUX COUPLING OUTSIDE DIAMETER	ISOFLUX COUPLING INSIDE DIAMETER	ISOFLUX COUPLING THICKNESS
IC-4200-90	3.07	10mm	F	1.97	4.92	1.38	0.98
IC-4300-95	3.25	3/8"	F	2.50	4.92	1.38	0.98
IC-4400-95	3.94	10mm	F	2.56	5.71	1.97	0.98
IC-4500-95	4.25	7/16"	F	2.50	5.91	1.77	1.13
IC-4500-HT	4.25	7/16"	F	2.50	5.91	1.77	1.13
<b>IC-4550-95</b>	<b>4.25</b>	<b>7/16"</b>	<b>F</b>	<b>2.50</b>	<b>5.91</b>	<b>1.77</b>	<b>1.13</b>
<b>IC-4550-HT</b>	<b>4.25</b>	<b>7/16"</b>	<b>F</b>	<b>2.50</b>	<b>5.91</b>	<b>1.77</b>	<b>1.13</b>
IC-4600-95	3.15	10mm	M	2.36	4.92	1.38	0.98
<b>IC-4700-95</b>	<b>3.75 (Rect)</b>	<b>7/16"</b>	<b>F</b>	<b>2.75</b>	<b>5.31</b>	<b>1.97</b>	<b>1.26</b>
<b>IC-4800-95</b>	<b>3.125 (Rect)</b>	<b>3/8"</b>	<b>F</b>	<b>2.38</b>	<b>4.92</b>	<b>1.38</b>	<b>0.98</b>
<b>IC-4900-95</b>	<b>4.75 (Rect)</b>	<b>1/2"</b>	<b>F</b>	<b>3.75</b>	<b>6.89</b>	<b>1.97</b>	<b>1.44</b>

Metric							
MODEL	GEARBOX FLANGE BOLT CIRCLE DIAMETER	GEARBOX FLANGE BOLT SIZE	GEARBOX FLANGE INDEX RING TYPE	GEARBOX FLANGE INDEX RING DIAMETER	ISOFLUX COUPLING OUTSIDE DIAMETER	ISOFLUX COUPLING INSIDE DIAMETER	ISOFLUX COUPLING THICKNESS
IC-4200-90	78.00	10mm	F	50.00	125.00	35.00	25.00
IC-4300-95	82.55	3/8"	F	63.50	125.00	35.00	25.00
IC-4400-95	100.00	10mm	F	65.00	145.00	50.00	25.00
IC-4500-95	107.95	7/16"	F	63.50	150.00	45.00	28.60
IC-4500-HT	107.95	7/16"	F	63.50	150.00	45.00	28.60
<b>IC-4550-95</b>	<b>107.95</b>	<b>7/16"</b>	<b>F</b>	<b>63.50</b>	<b>150.00</b>	<b>45.00</b>	<b>28.60</b>
<b>IC-4550-HT</b>	<b>107.95</b>	<b>7/16"</b>	<b>F</b>	<b>63.50</b>	<b>150.00</b>	<b>45.00</b>	<b>28.60</b>
IC-4600-95	80.00	10mm	M	60.00	125.00	35.00	25.00
<b>IC-4700-95</b>	<b>95.25 (Rect)</b>	<b>7/16"</b>	<b>F</b>	<b>69.85</b>	<b>135.00</b>	<b>50.00</b>	<b>32.00</b>
<b>IC-4800-95</b>	<b>79.38 (Rect)</b>	<b>3/8"</b>	<b>F</b>	<b>60.33</b>	<b>125.00</b>	<b>35.00</b>	<b>25.00</b>
<b>IC-4900-95</b>	<b>120.65 (Rect)</b>	<b>1/2"</b>	<b>F</b>	<b>95.25</b>	<b>175.00</b>	<b>50.00</b>	<b>36.50</b>

(Rect) = Rectangular

**BLUE** = chamfered ODs to make installation easier. **RED** = sold with Bushing Kits. **GREEN** = will work with Spicer configuration.

# GEARguard

COUPLINGS

## 4 BOLT - WORKING TORQUE RATINGS

### Imperial (ft-lb)

MODEL	HEAVY DUTY	MEDIUM DUTY	PLEASURE CRAFT
IC-4200-90	360	540	615
IC-4300-95	360	540	615
IC-4400-95	360	540	615
IC-4500-95	490	725	830
IC-4500-HT	855	1280	1445
IC-4550-95	315	470	535
IC-4550-HT	650	975	1105
IC-4600-95	270	405	465
IC-4700-95	435	650	725
IC-4800-95	225	335	380
IC-4900-95	870	1300	1445

### Metric (Nm)

MODEL	HEAVY DUTY	MEDIUM DUTY	PLEASURE CRAFT
IC-4200-90	500	750	850
IC-4300-95	500	750	850
IC-4400-95	500	750	850
IC-4500-95	675	1000	1150
IC-4500-HT	1180	1770	2000
IC-4550-95	435	650	740
IC-4550-HT	900	1350	1530
IC-4600-95	375	560	640
IC-4700-95	600	900	1000
IC-4800-95	310	465	525
IC-4900-95	1200	1800	2000

# GEARguard

COUPLINGS

## 6 BOLT - DIMENSIONS



Imperial							
MODEL	GEARBOX FLANGE BOLT CIRCLE DIAMETER	GEARBOX FLANGE BOLT SIZE	GEARBOX FLANGE INDEX RING TYPE	GEARBOX FLANGE INDEX RING DIAMETER	ISOFLEX COUPLING OUTSIDE DIAMETER	ISOFLEX COUPLING INSIDE DIAMETER	ISOFLEX COUPLING THICKNESS
<b>IC-6000-95</b>	<b>3.88</b>	<b>7/16"</b>	<b>M</b>	<b>2.50</b>	<b>5.91</b>	<b>1.97</b>	<b>1.25</b>
<b>IC-6000-HT</b>	<b>3.88</b>	<b>7/16"</b>	<b>M</b>	<b>2.50</b>	<b>5.91</b>	<b>1.97</b>	<b>1.25</b>
IC-6100-95	4.75	1/2" UNC	M	3.00	6.30	2.36	1.50
IC-6125-95	4.75	1/2" UNC	F	3.00	6.30	2.36	1.50
IC-6150-95	4.75	16mm SHCS	M	3.00	6.30	2.36	1.50
IC-6300-95	6.00	16mm SHCS	M	3.75	8.35	2.87	1.50
IC-6300-IV	6.00	16mm SHCS	M	3.75	8.35	2.87	1.50
IC-6400-95	6.00	16mm SHCS	M	3.75	7.68	2.87	1.50
IC-6400-HT	6.00	16mm SHCS	M	3.75	7.68	2.87	1.50
<b>IC-6500-95*</b>	<b>10.24</b>	<b>3/4" UNC</b>	<b>M</b>	<b>6.69</b>	<b>12.99</b>	<b>3.74</b>	<b>1.77</b>
<b>IC-6600-95*</b>	<b>8.07</b>	<b>16mm SHCS</b>	<b>M</b>	<b>5.12</b>	<b>10.24</b>	<b>3.74</b>	<b>1.50</b>

Metric							
MODEL	GEARBOX FLANGE BOLT CIRCLE DIAMETER	GEARBOX FLANGE BOLT SIZE	GEARBOX FLANGE INDEX RING TYPE	GEARBOX FLANGE INDEX RING DIAMETER	ISOFLEX COUPLING OUTSIDE DIAMETER	ISOFLEX COUPLING INSIDE DIAMETER	ISOFLEX COUPLING THICKNESS
<b>IC-6000-95</b>	<b>98.43</b>	<b>7/16"</b>	<b>M</b>	<b>63.50</b>	<b>150.00</b>	<b>50.00</b>	<b>31.75</b>
<b>IC-6000-HT</b>	<b>98.43</b>	<b>7/16"</b>	<b>M</b>	<b>63.50</b>	<b>150.00</b>	<b>50.00</b>	<b>31.75</b>
IC-6100-95	120.65	1/2" UNC	M	76.20	160.00	60.00	38.10
IC-6125-95	120.65	1/2" UNC	F	76.20	160.00	60.00	38.10
IC-6150-95	120.65	16mm SHCS	M	76.20	160.00	60.00	38.10
IC-6300-95	152.40	16mm SHCS	M	95.25	212.00	73.00	38.10
IC-6300-IV	152.40	16mm SHCS	M	95.25	212.00	73.00	38.10
IC-6400-95	152.40	16mm SHCS	M	95.25	195.00	73.00	38.10
IC-6400-HT	152.40	16mm SHCS	M	95.25	195.00	73.00	38.10
<b>IC-6500-95*</b>	<b>260.00</b>	<b>3/4" UNC</b>	<b>M</b>	<b>170.00</b>	<b>330.00</b>	<b>95.00</b>	<b>45.00</b>
<b>IC-6600-95*</b>	<b>205.00</b>	<b>16mm SHCS</b>	<b>M</b>	<b>130.00</b>	<b>260.00</b>	<b>95.00</b>	<b>38.10</b>

SHCS = Socket Head Cap Screw UNC = Unified Coarse

**BLUE** = chamfered ODs to make installation easier. **RED** = sold with Bushing Kits. **GREEN** = will work with Spicer configuration.

# GEARguard

COUPLINGS

## 6 BOLT - WORKING TORQUE RATINGS

### Imperial (ft-lb)

MODEL	HEAVY DUTY	MEDIUM DUTY	PLEASURE CRAFT
IC-6000-95	670	990	1140
IC-6000-HT	980	1460	1700
IC-6100-95	1800	2700	3070
IC-6125-95	1800	2700	3070
IC-6150-95	1800	2700	3070
IC-6300-95	2600	3900	4430
IC-6300-IV	2600	3900	4430
IC-6400-95	2170	3250	3700
IC-6400-HT	3280	4780	5400
IC-6500-95	6470	9700	Use Medium
IC-6600-95	4340	6500	Use Medium

### Metric (Nm)

MODEL	HEAVY DUTY	MEDIUM DUTY	PLEASURE CRAFT
IC-6000-95	925	1375	1575
IC-6000-HT	1350	2020	2350
IC-6100-95	2500	3750	4250
IC-6125-95	2500	3750	4250
IC-6150-95	2500	3750	4250
IC-6300-95	3600	5400	6120
IC-6300-IV	3600	5400	6120
IC-6400-95	3000	4500	5100
IC-6400-HT	4400	6600	7480
IC-6500-95	8950	13400	Use Medium
IC-6600-95	6000	9000	Use Medium

# GEARguard

COUPLINGS

## 8 BOLT - DIMENSIONS



Imperial							
MODEL	GEARBOX FLANGE BOLT CIRCLE DIAMETER	GEARBOX FLANGE BOLT SIZE	GEARBOX FLANGE INDEX RING TYPE	GEARBOX FLANGE INDEX RING DIAMETER	ISOFLEX COUPLING OUTSIDE DIAMETER	ISOFLEX COUPLING INSIDE DIAMETER	ISOFLEX COUPLING THICKNESS
IC-8100-95	7.50	16mm SHCS	M	6.00	10.83	3.74	1.50
IC-8100-HT	7.50	16mm SHCS	M	6.00	10.83	3.74	1.50
<b>IC-8200-95</b>	<b>7.50</b>	<b>16mm SHCS</b>	<b>M</b>	<b>6.00</b>	<b>9.53</b>	<b>3.74</b>	<b>1.50</b>
<b>IC-8200-HT</b>	<b>7.50</b>	<b>16mm SHCS</b>	<b>M</b>	<b>6.00</b>	<b>9.53</b>	<b>3.74</b>	<b>1.50</b>
IC-8300-95	6.00	16mm SHCS	M	3.75	7.68	2.87	1.50
IC-8400-95	7.87	16mm SHCS	M	4.33	10.83	2.95	1.50
IC-8400-HT	7.87	16mm SHCS	M	4.33	10.83	2.95	1.50
IC-8534-95	8.75	3/4" UNC	M	5.00	12.40	2.95	1.77
IC-8600-95	9.06	20mm	M	5.91	12.40	3.94	1.77
IC-8690-95	9.00	3/4" UNC	M	6.00	11.81	3.74	1.77
IC-8695-95	9.50	3/4" UNC	M	6.00	12.99	3.74	1.77
IC-8695-HT	9.50	3/4" UNC	M	6.00	12.99	3.74	1.77
IC-8700-95	11.02	7/8" UNC	F	7.87	13.98	2.95	1.97
IC-8800-95	13.39	1" UNC	M	7.09	17.91	5.12	2.36

Metric							
MODEL	GEARBOX FLANGE BOLT CIRCLE DIAMETER	GEARBOX FLANGE BOLT SIZE	GEARBOX FLANGE INDEX RING TYPE	GEARBOX FLANGE INDEX RING DIAMETER	ISOFLEX COUPLING OUTSIDE DIAMETER	ISOFLEX COUPLING INSIDE DIAMETER	ISOFLEX COUPLING THICKNESS
IC-8100-95	190.50	16mm SHCS	M	152.40	275.00	95.00	38.10
IC-8100-HT	190.50	16mm SHCS	M	152.40	275.00	95.00	38.10
<b>IC-8200-95</b>	<b>190.50</b>	<b>16mm SHCS</b>	<b>M</b>	<b>152.40</b>	<b>242.00</b>	<b>95.00</b>	<b>38.10</b>
<b>IC-8200-HT</b>	<b>190.50</b>	<b>16mm SHCS</b>	<b>M</b>	<b>152.40</b>	<b>242.00</b>	<b>95.00</b>	<b>38.10</b>
IC-8300-95	152.40	16mm SHCS	M	95.25	195.00	73.00	38.10
IC-8400-95	200.00	16mm SHCS	M	110.01	275.00	75.00	38.10
IC-8400-HT	200.00	16mm SHCS	M	110.01	275.00	75.00	38.10
IC-8534-95	222.25	3/4" UNC	M	127.00	315.00	75.00	45.00
IC-8600-95	230.00	20mm	M	150.01	315.00	100.00	45.00
IC-8690-95	228.60	3/4" UNC	M	152.40	300.00	95.00	45.00
IC-8695-95	241.30	3/4" UNC	M	152.40	330.00	95.00	45.00
IC-8695-HT	241.30	3/4" UNC	M	152.40	330.00	95.00	45.00
IC-8700-95	280.00	7/8" UNC	F	200.00	355.00	75.00	50.00
IC-8800-95	340.00	1" UNC	M	180.01	455.00	130.00	60.00

SHCS = Socket Head Cap Screw UNC = Unified Coarse

**BLUE = chamfered ODs to make installation easier. RED = sold with Bushing Kits. GREEN = will work with Spicer configuration.**

# GEARguard

COUPLINGS

## 8 BOLT - WORKING TORQUE RATINGS

### Imperial (ft-lb)

MODEL	HEAVY DUTY	MEDIUM DUTY	PLEASURE CRAFT
IC-8100-95	4950	7430	Use Medium
IC-8100-HT	6150	9220	Use Medium
IC-8200-95	3250	4880	Use Medium
IC-8200-HT	5700	8570	Use Medium
IC-8300-95	2170	3250	3700
IC-8400-95	5060	7600	Use Medium
IC-8400-HT	7600	11400	Use Medium
IC-8500-95	6150	9220	Use Medium
IC-8534-95	6150	9220	Use Medium
IC8600-95	6250	9380	Use Medium
IC-8690-95	6250	9380	Use Medium
IC-8695-95	6500	9770	Use Medium
IC-8695-HT	9650	14500	Use Medium
IC-8700-95	7250	10850	Use Medium
IC-8800-95	16300	24500	Use Medium

### Metric (Nm)

MODEL	HEAVY DUTY	MEDIUM DUTY	PLEASURE CRAFT
IC-8100-95	6850	10275	Use Medium
IC-8100-HT	8500	12750	Use Medium
IC-8200-95	4500	6750	Use Medium
IC-8200-HT	7900	11850	Use Medium
IC-8300-95	3000	4500	5100
IC-8400-95	7000	10500	Use Medium
IC-8400-HT	10500	15750	Use Medium
IC-8500-95	8500	12750	Use Medium
IC-8534-95	8500	12750	Use Medium
IC8600-95	8650	12975	Use Medium
IC-8690-95	8650	12975	Use Medium
IC-8695-95	9000	13500	Use Medium
IC-8695-HT	13350	20100	Use Medium
IC-8700-95	10000	15000	Use Medium
IC-8800-95	22500	33750	Use Medium

# GEARguard

COUPLINGS

## 10 BOLT - DIMENSIONS

Imperial							
MODEL	BOLT CIRCLE DIAMETER	SIZE OF BOLTS	INDEX RING TYPE	INDEX RING DIAMETER	GEARBOX FLANGE OUTSIDE DIAMETER	GEARBOX FLANGE INSIDE DIAMETER	ISOFLEX PART THICKNESS
IC-10325-HT	6.69	14mm SHCS	M	5.51	8.35	2.95	1.77
*0.70" T-bushing included							
Metric							
IC-10325-HT	170.00	14mm SHCS	M	140.00	212.00	75.00	45.00
*18mm T-bushing included							

## 10 BOLT - WORKING TORQUE RATINGS

Imperial (ft-lb)			
MODEL	HEAVY DUTY	MEDIUM DUTY	PLEASURE CRAFT
IC-10325-HT	3600	5400	6150
Metric (Nm)			
IC-10325-HT	5000	7500	8500



# SPICER U JOINT

FLANGE FLEX COUPLINGS

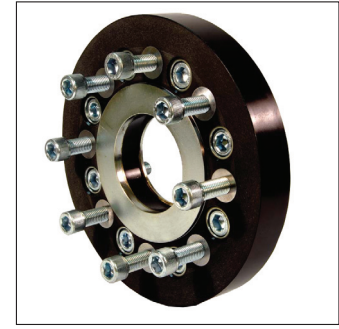

## DIMENSIONS

### Imperial

COUPLING	PCD (INS)	NO & SIZE OF BOLTS NXD	SPIGOT (INS)	FLANGE TYPE	OD (INS)	ID (INS)	THICKNESS (INS)	WEIGHT INCL. BOLT SET (lb)
IFC4700(95)	3.75	4 x 7/16" rect	2.75	F	5.315	1.969	1.3	3.1
IFC4800(95)	3.13	4 x 7/16" rect	2.38	F	4.921	1.378	1	1
IFC4900(95)	4.75	4 x 1/2" rect	3.38	F	6.89	1.969	1.4	1.4
IFC81610 HT	6.13	8 x 3/8"	6.63	F	8.66	1.969	1	1
IFC81710 HT	7.25	8 x 3/8"	7.75	F	9.49	2.93	1.2	1.2

### Metric

COUPLING	PCD (MM)	NO & SIZE OF BOLTS NXD	SPIGOT (MM)	FLANGE TYPE	OD (MM)	ID (MM)	THICKNESS (MM)	WEIGHT INCL. BOLT SET (kg)
IFC4700(95)	95.25	4 x 7/16" rect	69.85	F	135	50	32	1.4
IFC4800(95)	79.38	4 x 7/16" rect	60.33	F	125	35	25	1
IFC4900(95)	120.65	4 x 1/2" rect	85.73	F	175	50	36.5	2
IFC81610 HT	155.7	8 x 3/8"	168.28	F	220	50	25	2
IFC81710 HT	184.15	8 x 3/8"	196.86	F	241	74.4	30	2.4

## APPLICATIONS

SPICER FLANGE	COUPLING	SHORE A
1310	IC4800	95
1350	IC4700	95
1410	IC4700	95
1410	IC4700	HT
1480	IC4900	95
1510	IC4900	95
1550	IC4900	95
1610	IC81610	95
1710	IC81710	95
1710	IC81710	HT

# COUPLING CROSS REFERENCE

*GLOBE DRIVESAVER TO ISOFLEX*

DRIVESAVER	ISOFLEX	COMMENTS
303	n/a	
353	n/a	
354	n/a	
404	n/a	
404A	IC-4300-95	
404AC	IC-4300-95	2 5/8" Pilot Req'd
404V	IC-4600-95	
404S	n/a	
424Y	IC-4200-95	
4756	IC-6000-95	
4756PR	IC-6000-HT	
454	n/a	
504	IC-4500-95	
504A	n/a	
504AC	n/a	
504PR	IC-4500-HT	
504H	IC-4550-95	
504HPR	IC-4550-HT	
524Y	IC-4400-95	
554	n/a	
908	IC-8100-95	Iso 1/2" Thicker
908PR	IC-8100-95	Iso 1/2" Thicker
908S	IC-8200-95	Iso 1/2" Thicker
n/a	IC-8200-HT	Iso 1/2" Thicker
908AC	n/a	

DRIVESAVER	ISOFLEX	COMMENTS
1058	IC-8534-95	
1108	IC-8695-95	
1108A	IC-8690-95	
1308	n/a	
4756	IC-6000-95	
5756	IC-6100-95	Male Index Ring
5756A	IC-6125-95	Female Index Ring
5756APR	IC-6125-HT	Female Index Ring
5756AZF	IC-6100-95	Male Index Ring
5756AZFPR	IC-6100-HT	Male Index Ring
5756B	IC-6150-95	Iso 16mm Bolts No Bushing Kit Req'd
6256	n/a	
7256	IC-6300-95	
7256PR	IC-6300-HT	
7258ZPR	IC-8300-HT	
7306Z	IC-6400-95	
8078Z	n/a	
8010Z	IC-10325-95	Iso .27" Thicker
8858Z	n/a	

**ALWAYS CHECK TORQUE RATINGS**

# COUPLING CROSS REFERENCE

*POLY FLEX TO ISOFLEX*

POLY FLEX	ISOFLEX	COMMENTS
305	IC-3100-95	Toyota Previa - 12mm
306	IC-3200-95	Toyota Previa - 14mm
	IC-3300-95	Toyota Previa- Diesel
424(90)	IC-4200-90	
434(90)/(95)	IC-4300-95	
464(90)/(95)	IC-4600-95	
484(90)/(95)	IC-4800-95	
524(90)/(95)	IC-4500-95	
524FRL	IC-4550-95	
534(90)/(95)	IC-4400-95	
546(95)	IC-6000-95	
547(90)/(95)	IC-4700-95	
616-1/2 Bolts-M	IC-6100-95	
616-1/2 Bolts-F	IC-6125-95	
616-5/8 Bolts	IC-6150-95	
656	IC-6150-95	
1550	IC-4900-95	

POLY FLEX	ISOFLEX	COMMENTS & BUSHING KITS
2308	IC-8600-95	
2808	IC-8700-95	
3408	IC-8800-95	
7206-5/8 Bolts	IC-6300-95	
7206-3/4 Bolts	IC-6300-95	ITBK-19-6B
7606	IC-6400-95	
7606-3/4 Bolts	IC-6400-95	ITBK-19-6B
7608	IC-8300-95	
9114	IC-8200-95	
9114	IC-8200-95	ITBK-22-8B
9114 3+3 IRM	IC-8200-95	
9858 5/8	IC-8100-95	ITBK-22-8B
9858 3/4	IC-8100-95	ITBK-22-8B
9934	IC-8400-95	
10834	IC-8534-95	
11834A	IC-8690-95	
11834	IC-8695-95	

**ALWAYS CHECK TORQUE RATINGS**

# COUPLING CROSS REFERENCE

R&D TO ISOFLEX

R&D	ISOFLEX	COMMENTS & BUSHING KITS	ISOFLEX COUPLING THINNER BY INCHES
RA900-003	IC-6000-95		
910-001	IC-4300-95		0.30
910-002	IC-4200-95		0.30
910-005	IC-4300-95	Special Index Ring	0.37
910-006	IC-6150-95		0.37
910-007	IC-4600-95		0.74
910-009	IC-4500-95		0.65
910-012	IC-4400-95		0.79
910-013	n/a		n/a
910-014	IC-4300-95		0.30
910-015	n/a		n/a
910-016	n/a		n/a
910-017	IC-6400-95	ITBK-19-6B	0.89
910-018	IC-6400-95		0.89
910-019	IC-4600-95		0.30
910-020	IC-4600-95		0.30
910-021	n/a		n/a
910-022	IC-8200-95	ITBK-22-8B	0.25
910-024	IC-8534-95	ITBK-25-8B	0.46
910-025	IC-6100-95	Male Index Ring	0.46
	OR		
	IC-6125-95	Female Index Ring	0.68
910-026	IC-6150-95		0.46
910-027	n/a		0.00
910-028	n/a		0.00
910-029	IC-4500-HT		0.94
910-030	n/a		n/a
910-032	IC-6125-95/a	Female Index Ring	0.68

R&D	ISOFLEX	COMMENTS & BUSHING KITS	ISOFLEX COUPLING THINNER BY INCHES
910-033	IC-6150-95		0.68
910-034	IC-4500-95		0.65
910-035	n/a		n/a
910-036	n/a		n/a
910-037	IC-4500-95		0.89
910-038	n/a		n/a
910-039	IC-6400-95	ITBK-19-6B	0.99
910-040	IC-6400-95		0.99
910-041	n/a		n/a
910-042	n/a		n/a
910-043	IC-4200-90		0.30
910-044	IC-4500-95		0.65
910-045	n/a		n/a
910-046	IC-8100-95	ITBK-22-8B	0.25
910-047	n/a		n/a
910-048	IC-8100-95	ITBK-22-8B	0.97
910-049	n/a		n/a
910-050	IC-8200-95	ITBK-22-8B	2.50
910-051	IC-8695-95		0.53
910-052	IC-6000-95		1.49
910-053	n/a		n/a
910-054	IC-6100-95	Male Index Ring	0.37
	OR		
	IC-6125-95	Female Index Ring	0.68
910-055	IC-4300-95		0.79
910-057	IC-4500-HT		0.94
910-058	n/a		n/a
910-059	IC-4600-95		0.42

## ALWAYS CHECK TORQUE RATINGS

**NOTE:** Due to design parameters, R&D Couplings are usually quite a bit thicker than the comparable IsoFlex GEARguard Coupling. Please note these differences in the chart above before ordering. Installing the IsoFlex GEARguard Coupling may require other modifications to drive line components.

# TRANSMISSION CROSS REFERENCE

TWIN DISC TO ISOFLEX

TWIN DISC	ISOFLEX COUPLING	COMMENTS & BUSHING KITS
MG340, MG360, MG5010SC, MG5011SC, MG5010V	IC-4300-95	
MG5005A, MG5012C, MG5015A, MG5020SC and MG5055A	IC-4500-HT	
MG502-1, 502, 502A, 502V	IC-6000-95	
MG506, 506-1, 506-1A, 506SC, 5061, 5061A, 5062V	IC-6150-95 OR IC-6300-95	+ Adaptor
MG506DC	IC-6400-95	
MG507, MG507A-1 w/ 6" Flange	IC-6150-95	
MG507, MG507A-1 w/ 7 1/4" Flange	IC-6400-95	ITBK-19-6B
MG507SC	IC-6150-95	ITBK-19-6B
MG507-2, MG507A-2	IC-6400-95	ITBK-19-6B
MG509SC	IC-6400-95	ITBK-19-6B
MG509DC, MG509CP	IC-6400-95	ITBK-19-6B
MG510, MG510A, MG510SC	IC-8100-95 OR IC-8534-95	ITBK-22-8B + Adaptor
MG510DC	IC-8534-95	ITBK-25-8B
MG511, MG512, MG513, MG514SC	IC-8534-95	ITBK-25-8B
MG514DC, MG516DC, MG518, MG520, MG530, MG540	Contact IsoFlex	
MG5010A, MG5011A and MG5011SC	IC-4500	+ Adaptor
MG5010DC, MG5050V	IC-6150-95	

TWIN DISC	ISOFLEX COUPLING	COMMENTS & BUSHING KITS
MG5050A, MG5050SC	IC-6150-95	
MG5050	IC-6150-95	+ Adaptor
MG5061A, MG1061SC, MG5062V	IC-6150-95	
MG5065A, MG5065SC	IC-6400-95	ITBK-19-6B
MG5075A 6" Flange	IC-6150-95	
MG5075A with 7 1/4" Flange	IC-6400-95	ITBK-19-6B
MG5075SC	IC-6400-95	ITBK-19-6B
MG5081, 5081A, MG5082A and MG5082SC	IC-6400-95 OR IC-8100-95	ITBK-19-6B ITBK-22-8B
MG5085, 5085A, 5085SC, MG5090A, 5091, 5091A	IC-6400-95 OR IC-8100-95	ITBK-19-6B ITBK-22-8B
MG5095A, MGX5095A	IC-6450-95	Plus Special ITBK-20-6B
MG5091DC, MG509DC, MG5111DC, MG5114DC, MG5113 and MG514DC	IC-8534-95	ITBK-25-8B
MG5111DC, 5111A	IC-8100-95	ITBK-22-8B
MG5114A	IC-8200-95	ITBK-22-8B
MG5114SC	IC-8200-HT	ITBK-22-8B
MG5114DC	IC-8100-95	ITBK-25-8B
MG5135A	IC-8100-95	ITBK-22-8B
MG5141SC	IC-8100-95	ITBK-25-8B
MG5145A, MGX5145A and MGX5147A	IC-8400-HT	ITBK-24-8B
MGX5095A	IC-6400-95	Plus Special ITBK-20-6B

**Twin Disc Note:** Check torque ratings, especially on commercial applications. Bolt lengths may vary on the MGX transmission models as the pick-up ring on flange dictates. MG5081 may have interference from oil pump - check with IsoFlex.

# TRANSMISSION CROSS REFERENCE *ZF TO ISOFLEX*

ZF	ISOFLEX COUPLING	COMMENTS & BUSHING KITS
5M, 10M, 12, 12M, 15M, 15MA, 15MIV, 25M, 25MA, 30M, 25 and 25A	IC-4300-95	
45A, 450D, 45C w/ 4" Flange	IC-4300-95	
41, A2/A3, 45A	IC-4550-HT	
50A2/A3, 63,63A/IV HSW630V, ZF90IVTS	IC-4500-95	or IC-4500-HT
HSW800A2, HSW800A3 and 45-1 with 6" Flange	IC-6100-95	
80A, 85, 85IV	IC-6150-95	
220A	IC-6000-95	or IC-6000-HT
220V	IC-6300-95	
HSW220V-2, 800VI, 800V2, ZF110IVTS, 220IV, 80IV and 80-1IV	IC-6100-95	
280IV, 280-1, 280-1A, 285A, 285IV, 286IV, 301A and 301C	IC-6150-95	
HSW800A2, HSW800A3, 220, 280A and 280	IC-6150-95	
220	IC-6150-95	Spacer Required
300TS, 300-ITS, 300ATS, 300-IATS, 300VTS, 110ATS and 110IVTS	IC-6150-95	
220PL, 280V-LD, 280PL, 301PL-2 and 301A-2	IC-6150-95	

ZF	ISOFLEX COUPLING	COMMENTS & BUSHING KITS
302IV, 304A, 304C, 305-1	IC-8300-95	
305-2, 305-2A (10 Bolt)	IC-6300-95	+ Adaptor
311, 311A - Using 8 Bolt Flange	IC-8300-95	
302, 310, 311, 311A - all using a 10-Bolt Flange	IC-6300-95	+ Adaptor
320,320A, 320PL	IC-8500-95	+ Adaptor
325-1, 325-1A - 10 Bolt	IC-10325-HT	
325-1, 325-1A - 12 Bolt	IC-8200-95	+ Adaptor
350, 350A, 350V - 10 Bolt	IC-10325-HT	
350, 350A, 350V - 12 Bolt	IC-8200-95	+ Adaptor
350, 350A, 350IV, 350V (8 Bolt)	IC-8100-95	+ Adaptor
360, 360A - 10 Bolt	IC-10325-HT	
360, 360A - 12 Bolt	IC-8200-95	+ Adaptor
500A, 500IV	IC-8500-95	+ Adaptor
510A	IC-8500-95	+ Adaptor
550, 550A, 550V	IC-8500-95	+ Adaptor
665, 665A, 665V	IC-8500-95	+ Adaptor
2000, 2000A, 2000V	Contact IsoFlex	
2050, 2050A, 2050V	Contact IsoFlex	

**Notes:** Check torque in commercial applications. Flanges may vary depending on package or factory of origin's variations. New ZF25A may interfere with oil pump - IsoFlex coupling requires OD machining.

# TRANSMISSION CROSS REFERENCE

OTHER MANUFACTURERS

MANUFACTURER/ MODEL	ISOFLEX COUPLING	COMMENTS
<b>ALLISON</b>		
Allison M25	IC-8150-95	
Allison M	IC-6300-95	
Allison MH	IC-8150-95	
<b>BORG WARNER</b>		
BW70C	IC-4300-95	
BW71C 4"	IC-4300-95	
BW500	IC-4300-95	
BW1000	IC-4300-95	
BW1500	IC-4300-95	
BW71C 5"	IC-4500-95	
BW72C 5"	IC-4500-95	
BW VELVET DRIVE 5000A	IC-4500-95	
BW73C 6"	IC-6100-95	
BW 7000 SERIES	IC-6100-95	
<b>NOTE:</b> Borg Warner is now part of ZF Group		
<b>CAPITOL</b>		
7700 and many others	IC-8100-95	
<b>HARDY SPICER</b>		
SHAFT		
1310	IC-4800-95	
1350	IC-4700-95	
1410	IC-4700-95	
1480	IC-4900-95	
1510	IC-4900-95	
1550	IC-4900-95	
1610	TBA	
1710	TBA	
<b>HURTH</b>		
HBW/HSW 5, 10, 35, 40, 50, 100, 125	IC-4300-95	
HSW 150, 150A, 220, 250	IC-4300-95	
HSW 360, 360A, 400, 450,	IC-4500-95	
		450A - need Adaptor
HSW 600, 630, 630A1, 630H	IC-4500-95	
HSW 800A	IC-6100-95	
Note: If the model you are looking for is not here, please check the ZF Cross Reference.		

MANUFACTURER/ MODEL	ISOFLEX COUPLING	COMMENTS
<b>NEWAGE PRM</b>		
101, 140, 160, 260	IC-4500-90	
175, 265, 310, 401, 402,	IC-6125-95	
601 6" Flange	IC-6125-95	
1000 6" Flange	IC-6125-95	
601, 1000 4:1, 1200S, 1500S		
1500S, 1750S - 7 1/4" Flange	IC-6300-95	
PRM DELTA	IC-4300-90	
PRM 80	IC-4300-90	
PRM 120, 150	IC-4300-95	
PRM 260, 500	IC-6125-95	
PRM 750	IC-6125-95	
PRM 1000	IC-6150-95	
PRM 1200D, 1500D, 1750D	IC-8534-95 + 1" Bushing Kit	
PRM 1000 DROP CENTRE 4:1	IC-6300-95	
<b>NICO NAGATA</b>		
MGN 17B	TBA	
MGN 36	TBA	
MGN 46L	TBA	
MGN 56B	TBA	
MGN 56E	TBA	
MGN 76B1	TBA	
MGN 80E	TBA	
MGN133	TBA	
<b>PARAGON</b>		
4" Flange - 2.63" Spigot Req'd	IC-4300-SP	
<b>TECHNODRIVE</b>		
TMC30, TM40P, TMC50,		
TMC60 (All w/ 4" Flange)	IC-4300-90	
TMC60E	IC-4300-90	
TM260 4" Flange	IC-4300-90	
TMC93, 93A	IC-4500-95	
TMC345, 345A	IC-4500-90	
TMC485, 545A,	IC-4500-95	
TM170, 170A *	IC-4500-HT	
TM880A *	IC-4500-HT	
TM130B	IC-6150-95	

# TRANSMISSION CROSS REFERENCE

OTHER MANUFACTURERS

MANUFACTURER/ MODEL	ISOFLEX COUPLING	COMMENTS
<b>TECHNODRIVE (CONT.)</b>		
TM260, 265A	IC-6150-95	
TCM200B	IC-6400-95	
TM360 **	IC-8400-95	
TM1200A	IC-8300-95	
* Check Torque Calculations ** Check Pump Clearance		
<b>VOLVO</b>		
MS, MS2, MS10, MS15	IC-4600-95	
MS25 and RB	IC-4600-95	
MD10A	IC-4600-95	
2000 SERIES	IC-4600-95	
MD7A, TIC, 38	IC-4600-95	
MS3, MS4, MS4A, MS5	IC-4500-95	
HS25A, HS45A, HS63A	IC-4500-HT	
<b>YANMAR / KANSAKI</b>		
YSE8, YSME8, YSBE8		
YSE12, YSMW12, YSBE12	IC-4200-90	
20M,20H,20G	IC-4200-90	
JH-2-TF	IC-4200-90	
30M, 30H, 30G 4" flange	IC-4200-90	
30M, 30H, 30G 5" flange	IC-4400-95	
KBW10	IC-4200-90	
KM2P-1	IC-4200-90	
KM35A-2	IC-4200-90	
KM35P	IC-4200-90	
KBW20, KBW21	IC-4400-95	
KM4, KMH4, KMH4A	IC-4400-95	
KM4A-2	IC-4400-95	
KM5, KM5A	IC-4550-95	
KMH40	IC-4550-95	
KMH50A	IC-4500-HT	
KMH50V	IC-4500-HT	
KMH60A/61A	IC-6150-95	
KMH60V	IC-6150-95	
LH SERIES	IC-4500-95	
YXH160	IC-6600-95	
YXH180	IC-6600-95	
YXH240	IC-6600-95	
<b>Note:</b> KMH50 Transmission can see 1600Nm. Option is to use SAE #3 Flange with IC-6150-95.		



# GEARguard INSTALLATION INSTRUCTIONS

GENERAL

THE FOLLOWING “GENERAL” INSTALLATION INSTRUCTIONS COVER THE 4-BOLT, 6-BOLT AND 8-BOLT COUPLINGS. EACH COUPLING SHIPS WITH ITS OWN MODEL-SPECIFIC SET OF INSTRUCTIONS.

## STEP 1. CHECK FOR ALIGNMENT

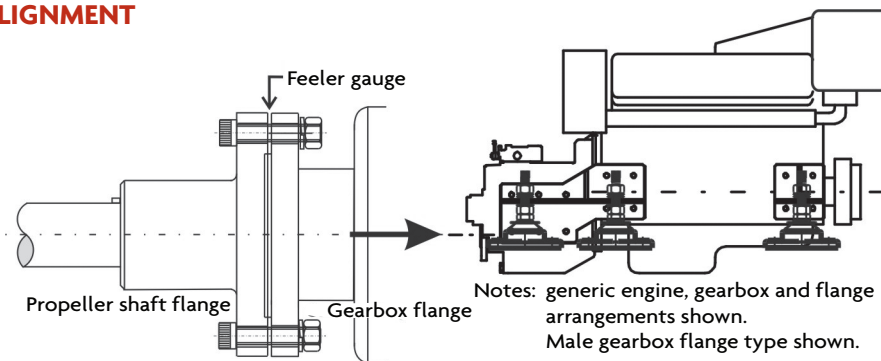

- Check existing alignment of flanges.
- Loosen the gearbox and propeller shaft flange bolts just enough to insert a feeler gauge between the flanges around the entire circumference of the parts.
- Align the flanges (using the adjusting nuts on the engine mounts) to within .003" (.07mm) around the circumference of the flanges.

## STEP 2. MEASURE THE INDEXING SURFACES – ISOFLEX COUPLING AND GEARBOX FLANGE

Male index ring gearbox flange type (M)

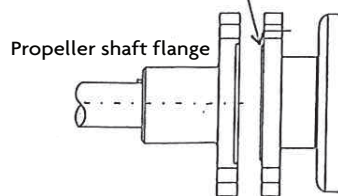

Female index ring gearbox flange type (F)

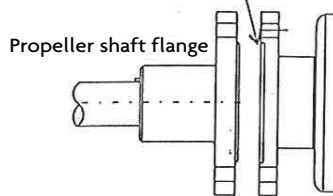

The index ring of the flanges (sometimes referred to as 'spigot' or 'pilot') maintains the concentricity of the power transmission shafts.

- Remove the flange bolts and separate the flanges from each other to a distance that allows you to position the IsoFlex coupling between the flanges.
- If the gearbox flange has a female index ring, press the male index ring of the IsoFlex coupling into the gearbox flange. The surface of the coupling should fit tightly against the gearbox flange. There should be no visible gaps between the mating surfaces.

# GEARguard INSTALLATION INSTRUCTIONS

GENERAL

- Next, press the female index ring of the IsoFlex coupling over the male index ring on the propeller shaft flange. Once again, there should be no visible gaps between the mating surfaces.
- If the IsoFlex coupling “stands away” from either flange in the drive train, the index rings have “bottomed out” which means the coupling will not function correctly. Stop the installation and call IsoFlex or your local distributor for assistance.

## STEP 3. CONNECT GEARGUARD COUPLING TO GEARBOX FLANGE

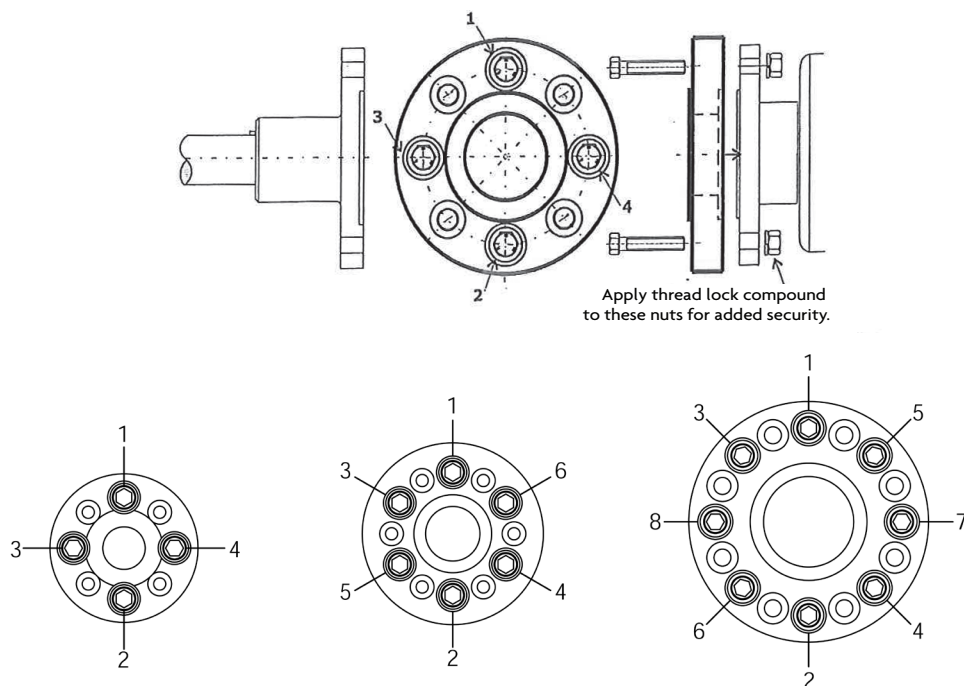

- Hold the IsoFlex coupling against the gearbox flange, mating the index features of both parts. Rotate the coupling to align the countersunk T-bushings in the coupling with the holes in the gearbox flange. Insert the “**longer**” bolts into the countersunk T-bushings and through the gearbox coupling. Place the lock washers over the bolts and affix the nuts. Apply some sort of thread lock liquid/paste (LOCTITE) to the threads before securing the nuts. **DO NOT add Loctite to the shorter bolts that bolt into the coupling itself.**
- Tighten these bolts to the required torque in two steps.

### 4-BOLT COUPLINGS, 6-BOLT COUPLINGS, 8-BOLT COUPLINGS

First, tighten (in the sequence shown in the drawing above) to half of the recommended torque rating for the bolts in your coupling. Then tighten (using this same sequence) to the final recommended torque rating. Lock washers should be fully compressed.

# GEARguard INSTALLATION INSTRUCTIONS

GENERAL

## STEP 4. CONNECT THE PROPELLER SHAFT FLANGE TO THE GEARGUARD COUPLING

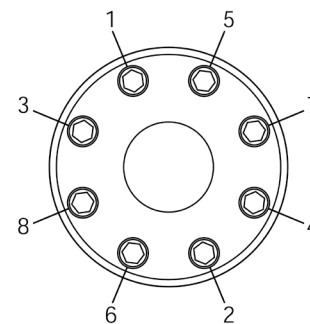
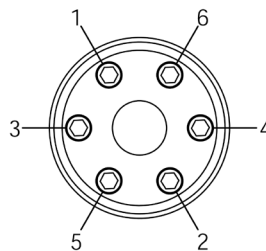
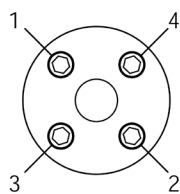
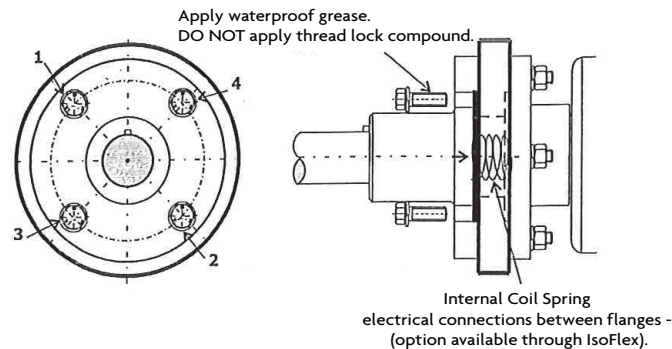

- Fit the propeller shaft flange to the IsoFlex coupling, rotating the propeller flange to align the remaining threaded inserts with the holes in the propeller shaft coupling.  
**To make it easier to remove the propeller shaft coupling in the future, apply a thin layer of waterproof grease to the threads before securing the bolts into the coupling.**
- Place lock washers onto the “shorter” bolts. Insert the bolts (with lock washers) through the propeller shaft coupling and thread into the threaded inserts in the IsoFlex coupling.
- Tighten these bolts to the required torque in two steps.

### 4-BOLT COUPLINGS, 6-BOLT COUPLINGS, 8-BOLT COUPLINGS

First, tighten (in the sequence shown in the drawing above) to half of the recommended torque rating for the bolts in your coupling. Then tighten (using this same sequence) to the final recommended torque rating. Lock washers should be fully compressed.

**NOTE: Over-tensioning ANY of the bolts during assembly (see torque charts on pages 9 and 29 for guidelines) may cause internal damage to the IsoFlex coupling. In extreme cases, the steel inserts may become distorted or spin within the coupling. The result is a coupling that will not function properly.**

## STEP 5. CHECK FOR RUN-OUT

Slowly rotate the shaft by hand with a dial indicator on the gearbox output flange – then the propeller flange. Run-out of approximately .004" (.01mm) is acceptable for most power transmission applications.

# GEARguard INSTALLATION INSTRUCTIONS

## GENERAL

### STEP 6. SEA TRIALS

Check the GEARguard coupling for heat build-up after 2 hours of sea trials. If the coupling is noticeably hotter than the gearbox flange (or if bolts have become loose), this is an indication that the flanges are misaligned. This needs to be corrected to avoid any damage to the coupling or other drive line components.

### STEP 7. RE-CHECK ASSEMBLY BOLTS IN THE PROPELLER FLANGE.

After approximately 15 hours of operation, re-check the bolts in the propeller shaft flange for torque accuracy.

## ADDITIONAL INSTALLATION NOTES

### A. Electrical Isolation

The IsoFlex GEARguard couplings electrically isolate the propeller shaft from the engine and gearbox. If you wish to connect the shaft to the engine, an internal coil spring (option available through IsoFlex) may be fitted as shown below.

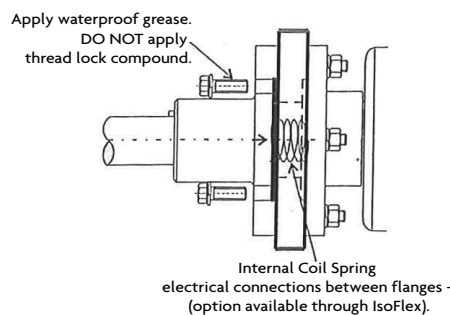

### B. Flange Misalignment

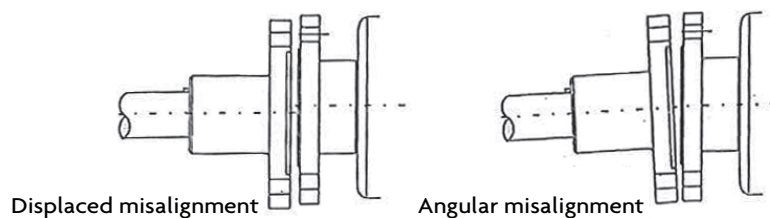

It is very important to check for misalignment of the gearbox and propeller shaft flanges. Both “displaced” and “angular” misalignment can be present in your installation. Please see diagrams above.

These types of misalignment should be minimized (maximum allowable between flanges being .004" or .010mm). Otherwise, service life of the IsoFlex GEARguard coupling will be noticeably reduced.

During normal operation, heat build-up in the coupling is an indicator that the system is misaligned.

# GEARguard INSTALLATION INSTRUCTIONS

GENERAL

## C. Adaptors

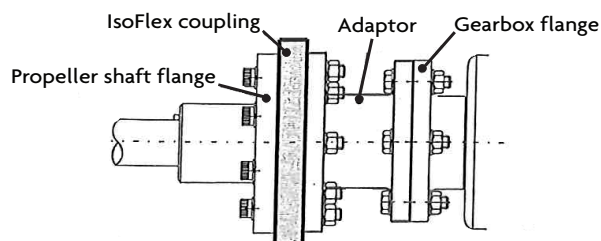

Some applications require an adaptor (sometimes referred to as a cotton reel or spool) to be fitted to the output flange of the gearbox. This adaptor will 1) move the GEARguard coupling far enough aft to clear any obstructions near the back of the engine (oil pumps, etc.) and 2) permit a different bolt pattern between the output flange and the required coupling.

Note the diagram above.

It is critically important to measure the index ring depths and heights to ensure that there is a minimum clearance of 0.020" (0.5 mm), ie. none of the index rings shall ever 'bottom out'.

If your installation requires an adaptor, IsoFlex recommends that it be manufactured by a marine engineering company from 1040 grade steel or equivalent and machined to industry tolerances and bolt hole clearances. Please check carefully for fit and run-out once installed.

## D. Dimensions and Tolerances

As gearbox manufacturers' dimensions and specifications are subject to change, it is necessary to check all dimensions to ensure the GEARguard coupling fits and works correctly.

All IsoFlex couplings are manufactured from engineering-grade polymers (thermoplastics). As a result, dimensional changes may occur depending upon ambient operating conditions.

Tolerances on all machined index rings: +/- .002" (+/- .05mm) @ 25° C.

All other dimensions: +/- .020" (+/- .5mm) @ 25°C.

## E. Bolt Kits - Recommended Assembly Torque

Imperial			
Coupling Bolt Size	Recommended Assembly Torque		High Tensile Grade AS 2465 / AS 1110
	ft-lbs	Nm	
3/8"	20	27	Grade 5 / Class 8.8
7/16"	32	43	Grade 5 / Class 8.8
1/2"	47	63	Grade 8 / Class 10.9
3/4"	155	210	Grade 8 / Class 10.9
7/8"	206	278	Grade 8 / Class 10.9
1"	250	338	Grade 8 / Class 10.9

Metric			
Coupling Bolt Size	Recommended Assembly Torque		High Tensile Grade AS 2465 / AS 1110
	ft-lbs	Nm	
8mm	10	14	Grade 5 / Class 8.8
10mm	31	42	Grade 5 / Class 8.8
12mm	34	46	Grade 8 / Class 10.9
14mm	65	88	Grade 8 / Class 10.9
16mm	83	112	Grade 8 / Class 10.9
20mm	150	200	Grade 8 / Class 10.9

---

# NOTES

---

# NOTES

---

# IsoFlex<sup>TM</sup>

MINIMIZING

VIBRATION



IsoFlex Technologies Pty Ltd.  
Unit 33, 75 Waterway Drive  
Gold Coast Marine Precinct  
Coomera, Queensland  
Australia 4209

Phone + 61 7 5556 0924

Fax + 61 7 5556 0984

[info@isoflex.com.au](mailto:info@isoflex.com.au)

[www.isoflex.com.au](http://www.isoflex.com.au)

[www.isoflextech.com](http://www.isoflextech.com)

ISOFLEX COUPLING AU (Rev. 7/5/12)

# GEARguard

FLEX COUPLINGS